

**GAMCO INC.**  
CONCRETE FORMS & SHORING  
[www.gamcoform.com](http://www.gamcoform.com)  
PHONE: 513-561-8331

# Steel-Ply®

FORMING SYSTEM



**SYMONS**  
BY DAYTON SUPERIOR

# Steel-Ply® Forming System



The Steel-Ply forming system is a pre-engineered, factory-built, reusable concrete forming system. It may be used in handset or gang form applications, for commercial or residential structures. The Steel-Ply forming system can form walls of almost any shape or size, with accessories for special structures and details. This system is more productive and economical than job-built plywood formwork or other forming methods.

## **Steel-Ply saves time**

The Steel-Ply forming system saves time because it is easy to set up and strip. No measuring, sawing, drilling, or nailing is required. Minimal training is needed, so workers are quickly up to maximum efficiency. The only tool required for setup and stripping is a hammer.



## **Steel-Ply saves materials**

Unlike job-built formwork, which must be tailored for each specific pour, the Steel-Ply forming system comes in a variety of standard sizes which can be combined to form virtually any dimension. Steel-Ply panels and fillers are made of specially laminated plywood mounted on rugged steel frames. They can be used up to 200 times before being re-plyed.

## **Quality, consistency and safety**

No matter what the application, the same basic components and methods are used. Labor performance becomes consistent and predictable, and the laminated plywood panels and tight-fitting side rails produce a high quality concrete surface. This engineered system is designed and manufactured with a known strength factor, a major consideration for job-site safety.



### **Superior service**

The complete Steel-Ply® forming system is available through a worldwide network of Symons Branches, Dealers and Distributors. Each Branch and Distributor is staffed with Symons representatives who are trained and experienced in concrete forming. These representatives can work with you to develop detailed formwork layout drawings which show component placement and reuse cycles. This includes a complete bill of materials to ensure that all essential elements are available when the job starts.

On-the-job crew training, application consultation, safety tips and Application Guides are also available. This extra assistance helps crews work rapidly, efficiently, and safely during the project.

### **Rent or purchase**

All standard panel sizes and most accessories are available for rental or purchase. This is especially advantageous if you have an unusually large or unique job where purchasing a system is not practical. Another option is to buy the basic panels and accessories and rent some of the specialized components as the need arises.

Let a Symons representative prepare an analysis to determine if the rental or purchase of the Steel-Ply forming system is appropriate for the specific application.





# Quick-Hook™ Handle

## Quick-Hook Handle

The Steel-Ply® panel is also available with a patented Quick-Hook™ Handle design. This exclusive design meets the Occupational Safety and Health Administration (OSHA) 5000 lb. capacity requirement for fall protection (Subpart M).

The Quick-Hook Handle is integral to the panel design with staggered locations between the crossmembers. This provides convenient climbing and attachment points for personal safety equipment. This design improves worker safety without any reduction in productivity.

The same Quick-Hook Handle is used to carry the panel. The design provides enough clearance for hands, but does not interfere with panel stacking for storage.

When a Quick-Hook Handle is not accessible, the installation of Safety Eyes on any Steel-Ply panel allows easy attachment of personal safety equipment. Safety Eyes are attached to vertical siderails to provide safe climbing points on gang form applications.

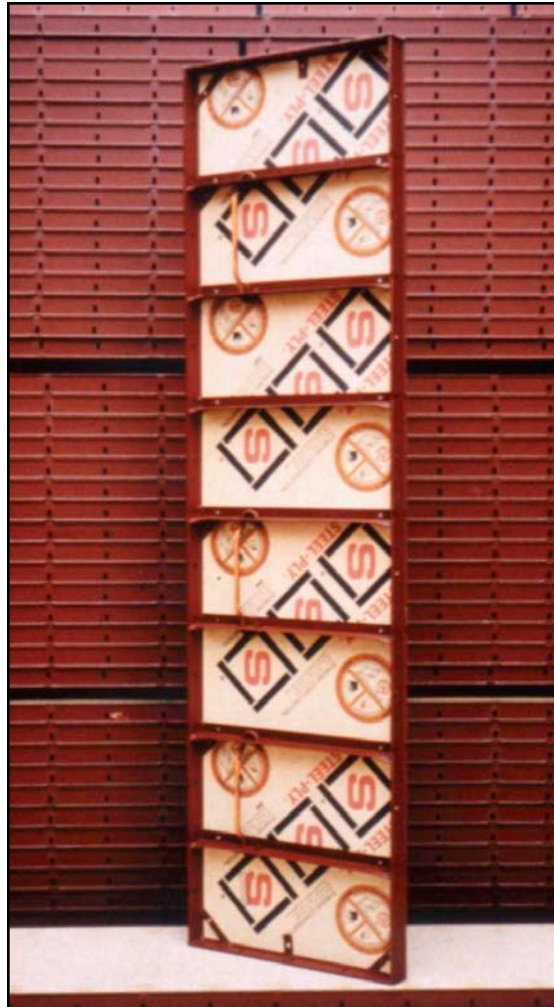

# Connecting Hardware

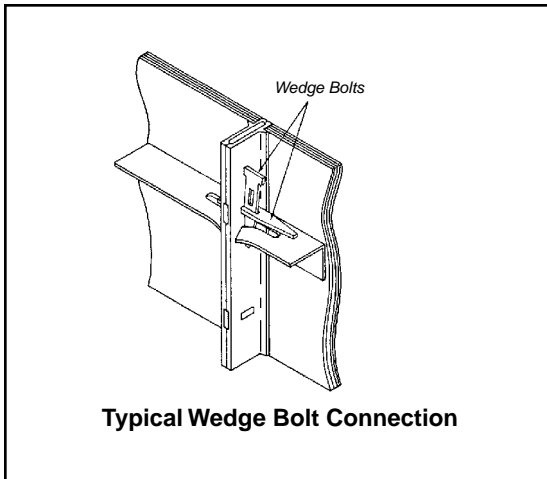

For productive setting and stripping of forms, Symons offers a variety of connecting hardware.

## Wedge Bolts

Two identical Wedge Bolts function as a lock-bolt set, one as a connecting bolt, the other as a clamping wedge. At typical siderail-to-side-rail connections, the loop end of the tie is positioned in dado slots and is secured by the same Wedge Bolts.

For typical walls, form connecting Wedge Bolts are only required at standard tie connection positions. Additional Wedge Bolts are utilized at other positions for attachment of walers, scaffold brackets or other accessory components.

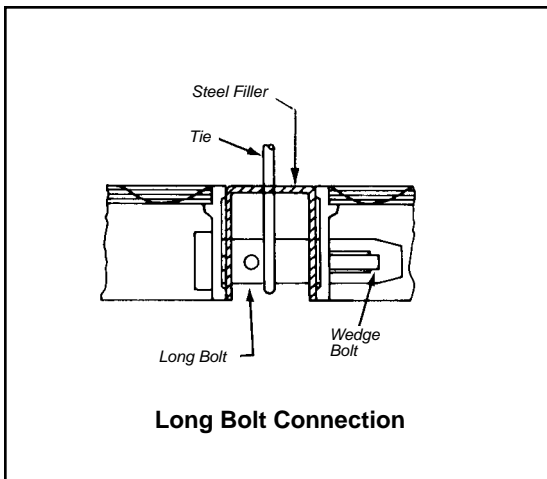

## Long Bolts

The Long Bolt is designed to be used with the 1", 1½" and 2" Steel Filler. The long connecting bolt is punched with two ¼" holes to accommodate a 16D nail to be used to shorten the bolt for Steel Fillers. A vertical Wedge Bolt secures the two panels and filler through the adjoining side rails.

## Adjustable Long Bolts

The Adjustable Long Bolt is designed to allow two steel fillers to be used side-by-side. It can accommodate up to a 3" combination (i.e. two 1½" steel fillers, or a 1" with a 2" steel filler).

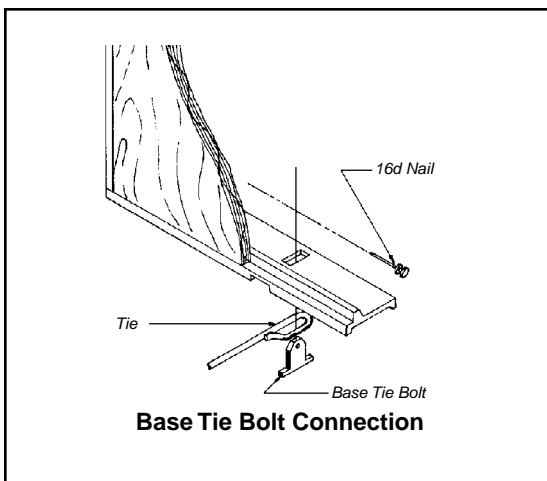

## Base Tie Bolts

The Base Tie Bolt secures a tie to an endrail or a siderail resting on a footing. It also can be used in situations where panels butt against an existing vertical surface.

Symons has the largest selection of standard and special ties in the industry. Wire ties and flat ties are used for standard Steel-Ply® tie spacing, and reusable load-gathering She-Bolts and Taper Ties are used for wider tie spacing.

## S-Panel Ties

The S-Panel Tie, or wire tie, is the most commonly used tie for commercial and industrial structures. The standard breakback for the S-Panel Tie is 1", with other breakbacks available upon request. The S-Panel Tie can be manufactured to almost any length, with optional cones and water resistant washers to meet job specifications.

## X-Flat Ties

X-Flat Ties are commonly used for residential foundations when the 1" standard breakback is not required. The end of the tie extends beyond the back of the form for quick inspection of tie location.

## Threaded Ties

The Threaded Tie provides adjustment advantages for battered walls. Threaded Ties have a special thread design to gain maximum strength using the maximum diameter thread possible with Symons standard wire tie.

## S-Base Tie

The S-Base Tie has an upturned loop at each end which projects up through the bottom rail. Wedge Bolts are inserted through the loop end to secure the tie and panel. The S-Base Ties are used for small retaining walls or against existing walls.

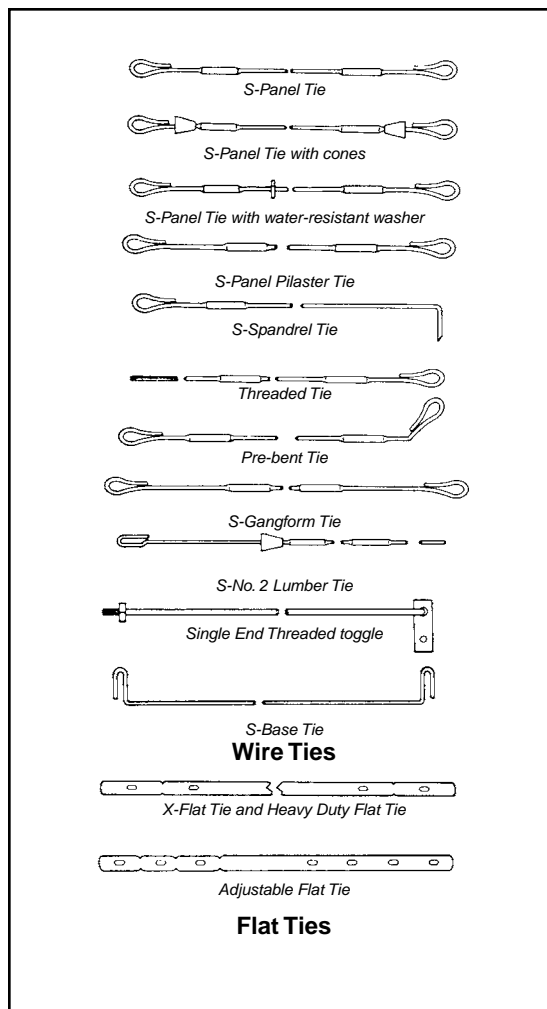

# Corners

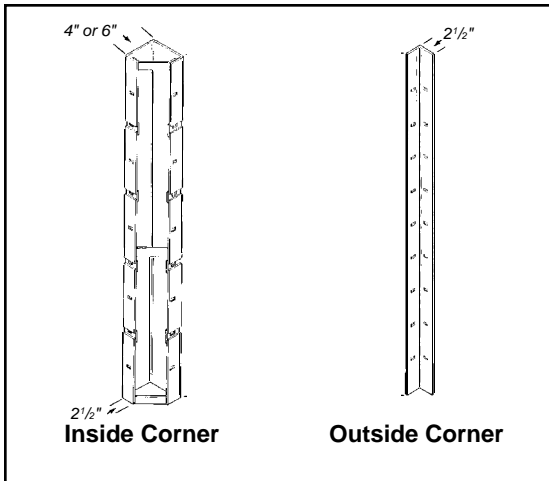

## Inside and Outside Corners

Inside and Outside Corners are all-steel corners that lock adjoining forms together to make a 90° angle.

Standard Inside Corners have a face dimension of 4" x 4" or 6" x 6". Each Inside Corner is manufactured with reinforcing straps to maintain 90°. Dadoes are placed 12" O.C. for tie connection and slots are placed 12" O.C. for connecting hardware.

## Bay Corners

Inside Bay Corners opposite Outside Bay Corners form a 135° angle.

The Inside Bay Corner has a 3" x 3" face dimension, and the Outside Bay Corner has a 7" x 7" face dimension. Ties connect at adjoining panel joints to complete this forming detail.

Bay Corners can also be used horizontally to form wall haunches and "Y" walls.

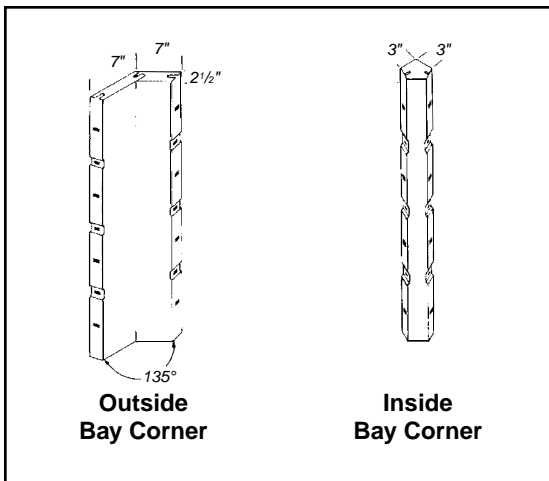

## Hinged Corners

The Inside Hinged Corner may be used to form inside corners down to a 45° angle. The Outside Hinged Corner forms outside corners from 135° down to a 5° angle.

In most wall applications, Inside Hinged Corners are used opposite Outside Hinged Corners. Always insert connecting Wedge Bolts toward the adjoining panels so that the angle will not be restricted.

Corners must always be adequately waled, braced and blocked as required.

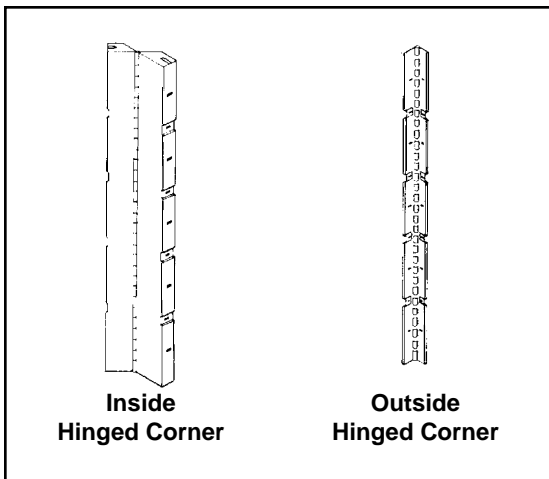

# Waler and Strongback Hardware

The strength of the panel design makes a waler necessary for alignment only, it is not a structural part of the formwork. Only one row of 2" x 4" walers on each tier of panels is required, with a variety of time and material saving attachment options available to increase your productivity.

## One-Piece Waler Bracket

The One-Piece Waler Bracket is fast and simple to install. Just insert the Waler Bracket into any siderail hole not being used for ties, place a single or double 2" x 4" piece of lumber on top of the bracket, and drop the attached wedge into position. No additional hardware is needed.

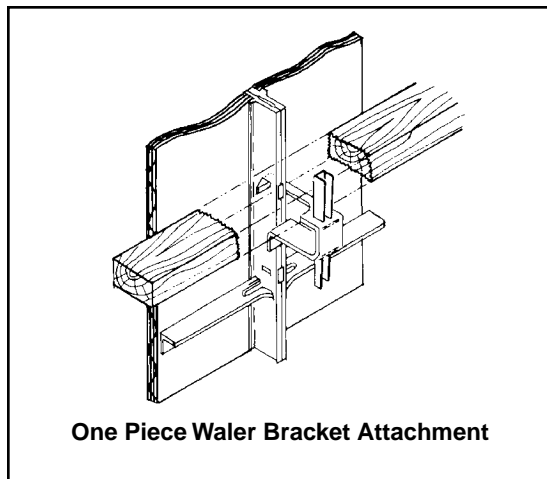

## Z-Tie Holder

The Waler Tie and Z-Tie Holder combination is another method of attaching walers. Waler Ties are available in two lengths to secure double 2" x 4" or double 2" x 6" lumber walers. Once the Waler Tie is fastened with Wedge Bolts, the lumber is positioned and the Z-Tie Holder is used to complete the assembly.

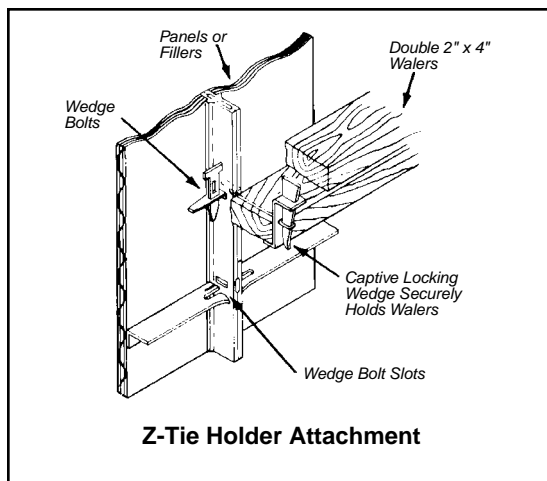

## Strongbacks

Strongbacks are vertical alignment members that are placed at 90° to walers. The Strongbacks are used to align the walers and are commonly placed at 8' O.C. Strongbacks can be doubled 2" x 4", 2" x 6" or 2" x 8" lumber secured with J-Strongback Hooks.

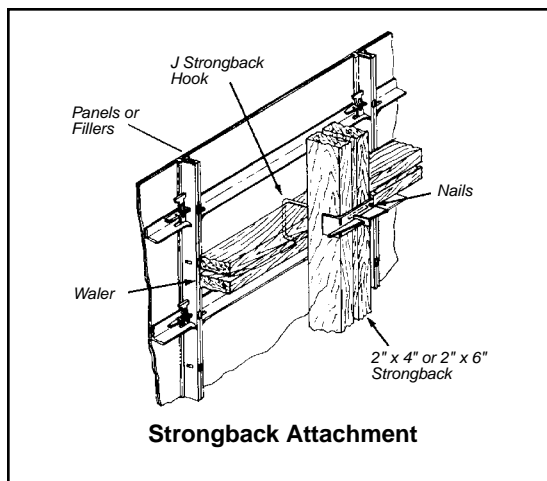

# Form Alignment

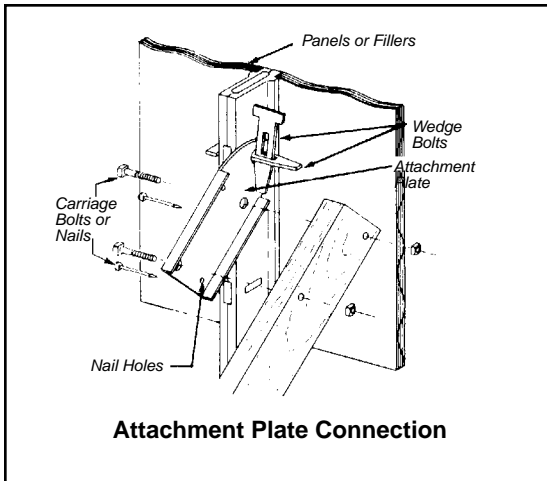

Aligners are required to position forms, they are not intended to be used as bracing or to resist concrete pressure.

## Attachment Plate

The Attachment Plate can be bolted or nailed to 2" x 4" lumber. Aligners are quickly attached or removed from the forms with standard connecting hardware.

## Turnbuckle

Turnbuckles allow for 6" length adjustment. The Turnbuckle is attached with nails to lumber and anchored before final adjustments are made. The end of the Turnbuckle contains a large slot to accommodate a Steel Stake.

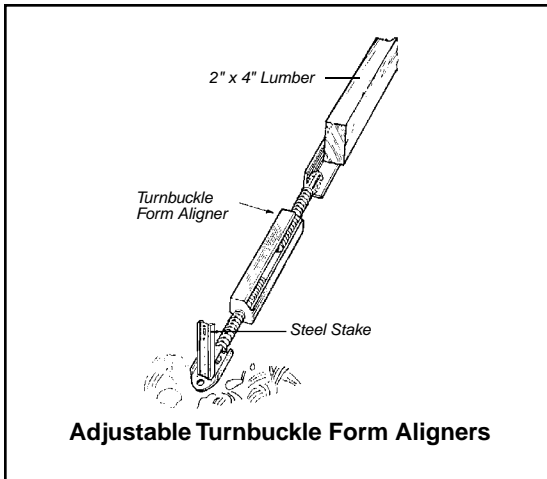

## Pipe Form Aligner

The Pipe Form Aligner eliminates the use of lumber and allows adjustments from 13'-4" to 20'-9". The top end of the Pipe Form Aligner uses a Steel-Ply® Adapter Plate which connects to the Steel-Ply panel. The bottom of the Pipe Form Aligner requires a Pipe Form Aligner Shoe for anchoring a 3/4" diameter concrete anchor or a Steel Stake.

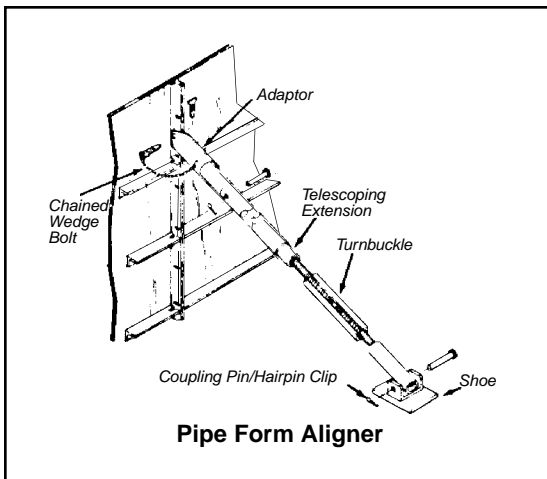

# Scaffold Brackets

## Scaffold Bracket

Scaffold Brackets are installed where one or more levels of work platform are required for personal safety. The maximum safe load of the Scaffold Bracket is 500 lbs. (4 to 1 safety factor).

The Scaffold Bracket comes with a wedge and cable attachment for quick assembly.

*Note: Do not use Scaffold Brackets to support cantilevered concrete soffit forms, or for temporary storage of construction equipment or material.*

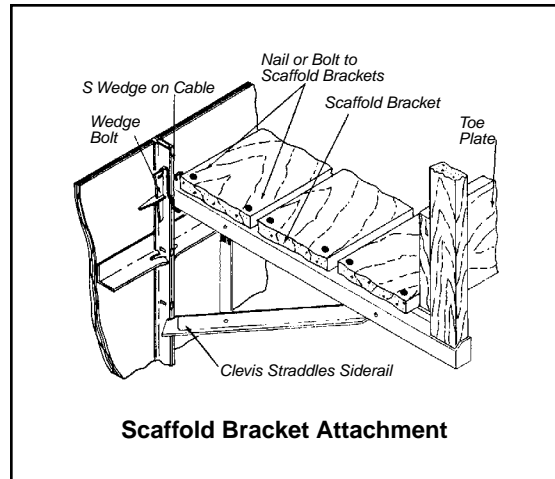

## Filler Angle

Filler Angles provide a means to construct a custom size filler with  $\frac{3}{4}$ " plywood that can be connected to the side rails of adjoining Steel-Ply® forms.

These Filler Angles are recommended where reinforcing steel, pipes, or other penetrations must protrude through the form face.

## Steel Filler

Steel Fillers are cold-formed U-shaped steel. The 1" and 1½" steel fillers are punched with connecting slots at 6" O.C. A Long Bolt passes through the steel filler to grip adjoining panel side rails.

The 2" Steel Filler has connecting slots at 2" O.C. It is used to "step" forms in 2" increments. This steel filler reduces the need to build up under forms when step footings or changing wall elevations occur.

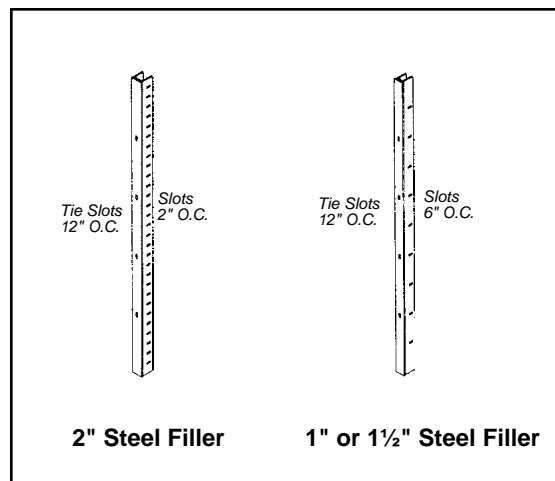
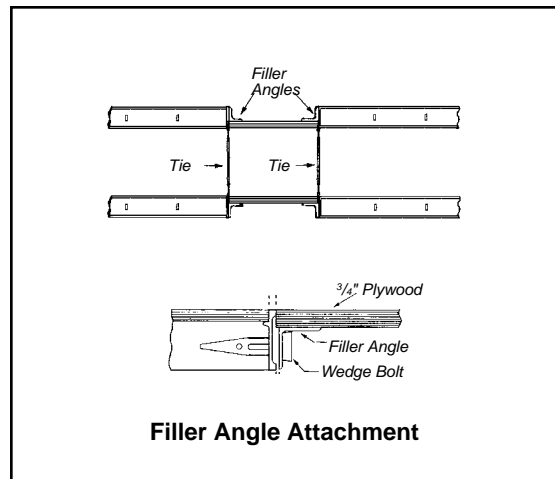

# Pilasters and Culverts

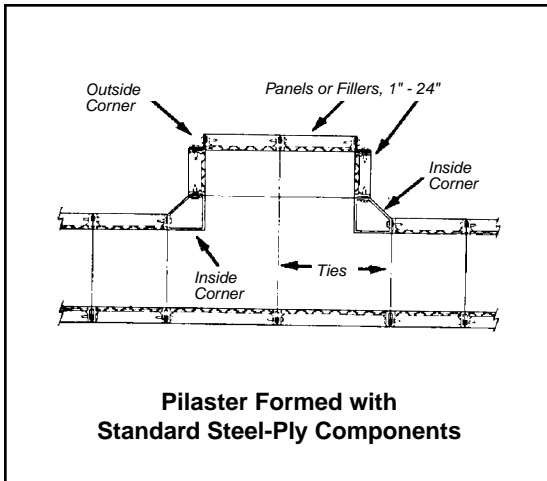

## Pilaster

Pilasters of almost any dimension are formed quickly and easily using standard Steel-Ply® panels or fillers with Inside Corners and Outside Corners.

## Adjustable Pilaster Form

An Adjustable Pilaster Form is available to form standard pilasters from 1" to 12" deep in 1" increments. The Pilaster Form eliminates Inside and Outside Corners and the need for having specific size fillers on hand. The Pilaster Brace eliminates lumber bracing to maintain right angles.

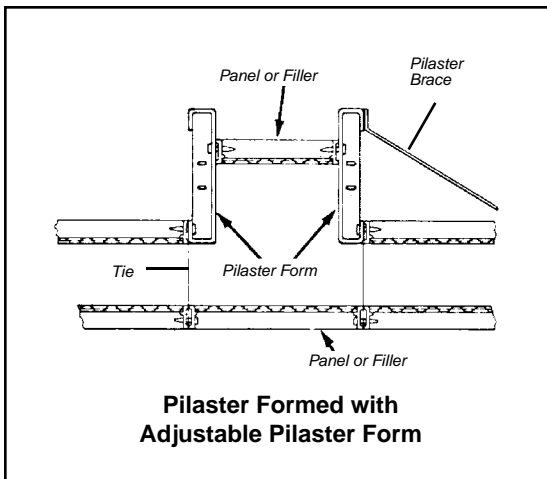

## Culvert Form

Reusable steel Culvert Forms come in lengths of 3', 4', 6' and 8', and widths of 6", 9" and 12". The Culvert Form permits monolithic pouring of the walls and elevated slab of culvert structures. The Culvert Form can also be used to make chamfered corners in vertical walls.

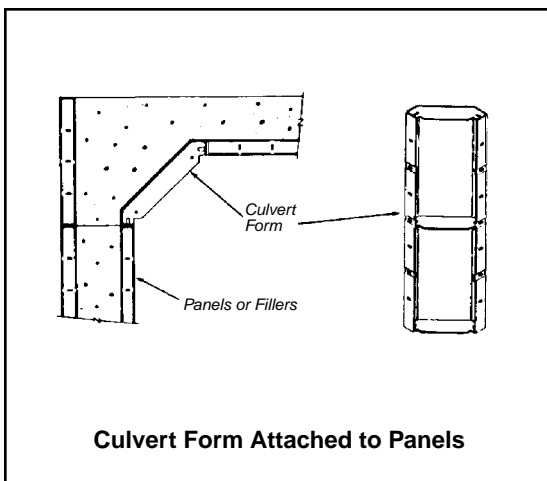

## Double Duty Lift Bracket

The Double Duty Lift Bracket provides an attachment point for rigging and handling gangs. A vertical capacity of 2000 lbs. (5 to 1 safety factor) meets OSHA requirements.

Application drawings show locations and numbers of Double Duty Lift Brackets per gang.

*Note: Do not break a gang form loose from a wall by lifting or tugging backwards with the Double Duty Lift Bracket.*

## Waler Lift Bracket

The Waler Lift Bracket is an alternative device for lifting gangs. A vertical capacity of 4000 lbs. (5 to 1 safety factor) meets OSHA requirements.

*Note: Only vertical loads can be imposed at lift holes for the Waler Lift Bracket. A Lift Beam with vertical drop lines connected to Waler Lift Brackets must be used.*

## Column Lift Corner

The Column Lift Corner can be used as the outside corner in the top two feet of ganged columns. The Column Lift Corner extends 4" above the column and is secured with Wedge Bolts. Two Column Lift Corners are required per column. The Column Lift Corner has a safe load capacity of 2000 lbs.

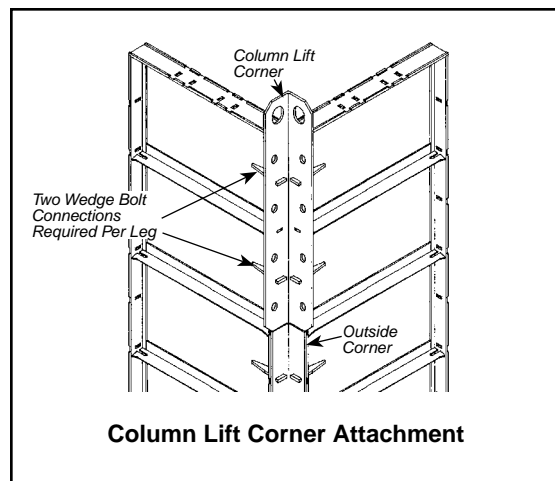
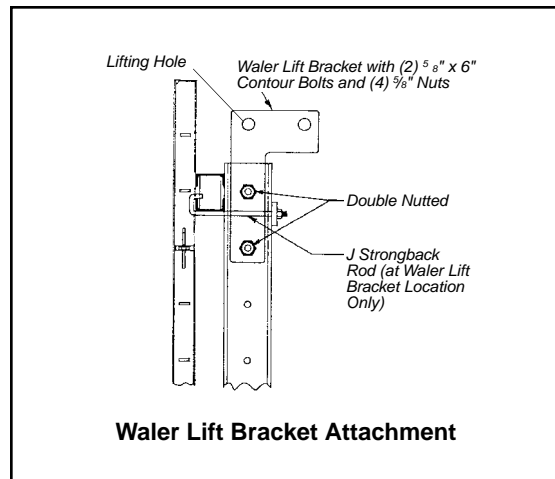
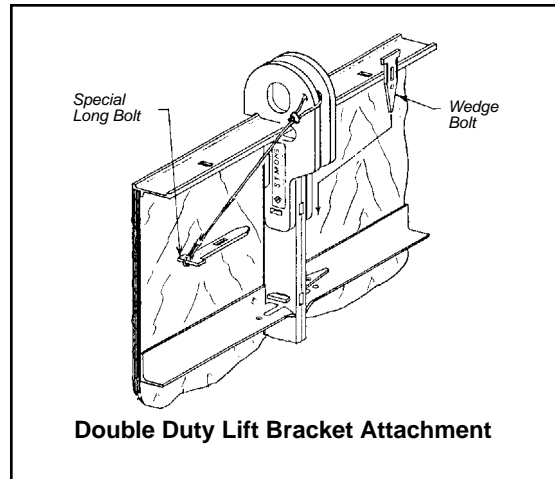

# Accessories

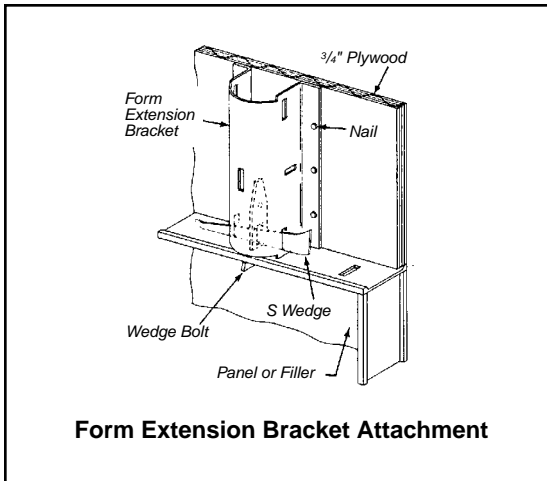

## Form Extension Bracket

The Form Extension Bracket is a convenient means to extend the height of a standard panel an additional 3" to 12" for straight or curved walls. The bracket is designed to be used with 3/4" plywood and attached with a Wedge Bolt. The bolt comes up from the top rail of the panel below and is locked in with an S-Wedge. A slot in the center of the bracket allows for Waler attachment.

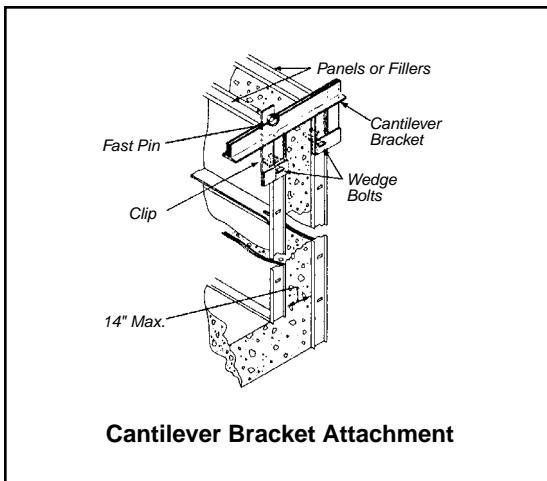

## Cantilever Bracket

The Cantilever Bracket is used to suspend a form on the opposite side of the wall. This allows different elevations at the bottom of forms so that a base slab can be monolithically poured with the wall. Maximum capacity is 700 lbs. Maximum spacing must not exceed panel length when forms are horizontal, and must not exceed 8'-0" when panels are vertical.

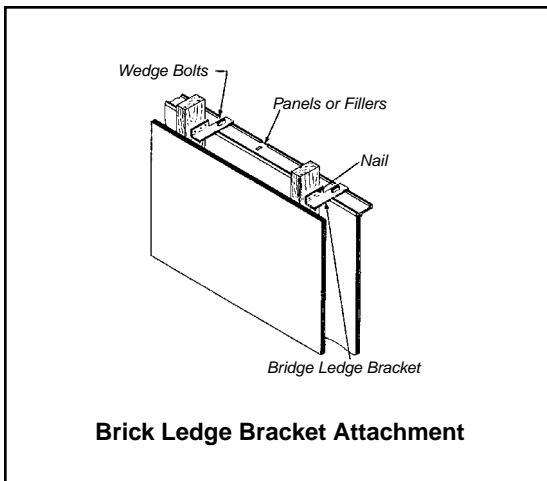

## Brick Ledge Bracket

The Brick Ledge Bracket is used to form brick ledges and support various framed boxouts. The bracket is attached to panels or fillers with Wedge Bolts. The bracket spans the wider side of a 2" x 4" piece of lumber to create the offset needed.

### Bulkhead Forming

Keyway Forms come in 3', 4', 5', 6' and 8' lengths. When bolted to Bulkhead Bars, they produce a keyway and hold the waterstop in position.

Bulkhead bars can be used for forming bulkheads in walls 4" to 24" wide. Standard Wedge Bolts attach the bars to the siderails of panels and fillers.

Bulkheads can also be formed by using Outside Corners and a panel or filler.

### Haunch Forming

Haunch Brackets provide an ideal way to form haunches or corbels, without any additional lumber support.

The Haunch Bracket connects easily with Steel-Ply® panels and is designed to support 3/4" plywood. Slots make securing walers a simple operation.

### Footing Corner Bracket

Forming footings, pads and slabs is made easy with the Footing Corner Bracket. Attached at the top and bottom of each corner, Footing Corner Brackets hold the panels firmly. A wide range of dimensions in 2" increments is possible.

Stake Plates are then positioned along the top edge of the Steel-Ply for Steel Stakes. The Stake Plates are typically located midway between Steel-Ply crossmembers and endrails to provide access for a stake puller.

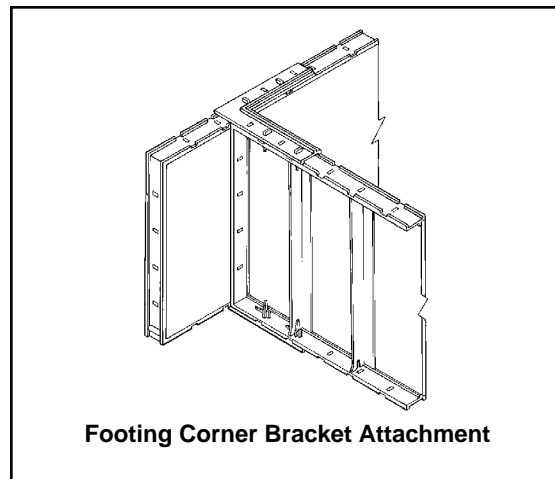
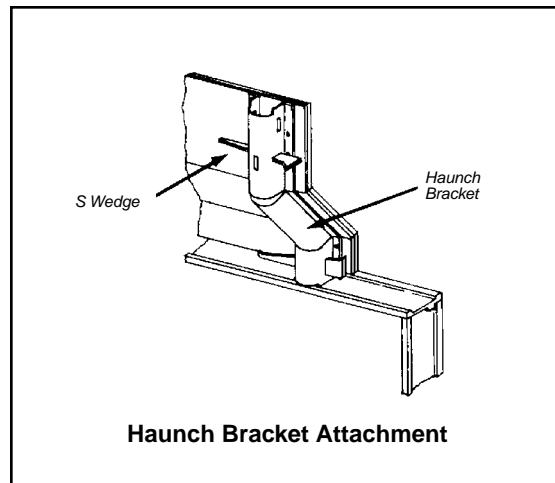
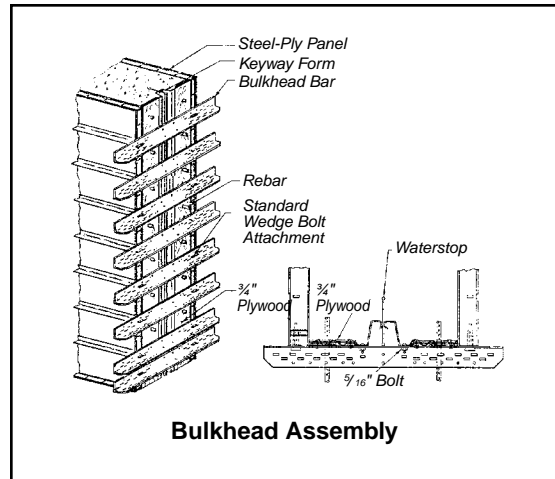

# Column Forming

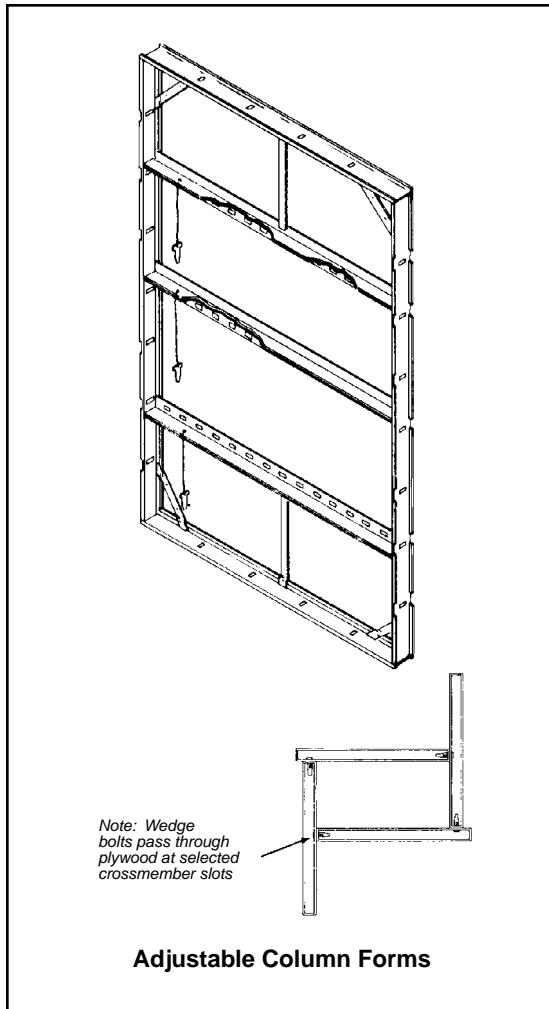

## Adjustable Column Form

The Adjustable Column Form is for columns up to 30" square, in 1" increments (except 28" and 29" increments). For columns 27" or less, sizes are accommodated by placing the panels in an overlapping manner. In these instances,  $\frac{3}{4}$ " holes must be drilled through the plywood at the appropriate connection bolt slot in the crossmember for the hardware.

Outside Corners and standard Steel-Ply panels or fillers may be used in conjunction with the Adjustable Column Form for other column dimensions.

### Column forming

The Steel-Ply® forming system provides several ways to form columns of various shapes and sizes. Outside Corners and panels or fillers can be combined to form square or rectangular columns. This method proves faster and more accurate than job-built forms. Wedge Bolt connections help square corners and speed assembly and stripping.

### Column Hinge

The Column Hinge is used to set and strip Steel-Ply column forms more efficiently. Column formwork can be handled as a single unit that is “closed” around reinforcing steel and “opened” after concrete is placed.

The Column Hinge makes forming crews very productive when there are repetitive concrete column designs in commercial and industrial structures.

### Quick Column Hardware

The Quick Column Hardware is used in combination with the Column Hinge for even faster column forming. The hardware attaches to the Steel-Ply Outside Corner opposite the Column Hinge to provide a fast closure and release.

With this method, there is no loose hardware to consider during the column forming sequence. Everything remains connected to the column formwork for maximum productivity.

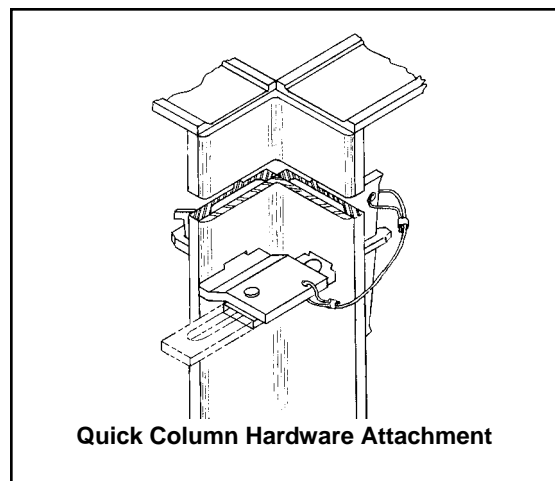
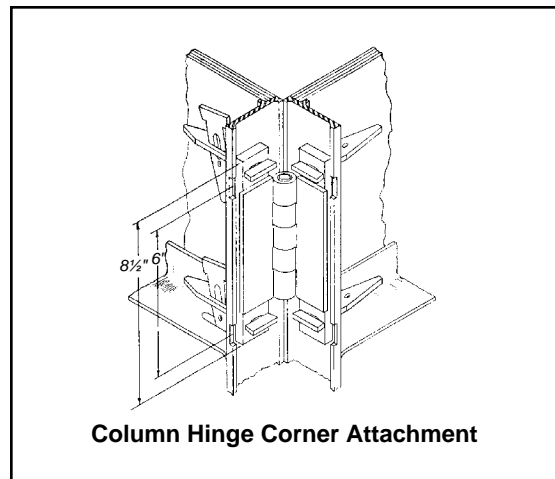
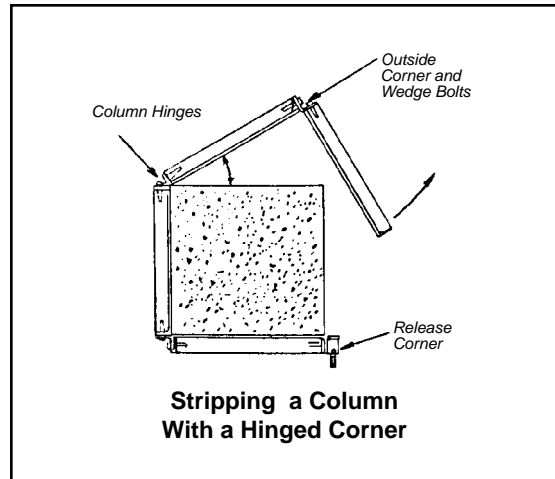

# Conventional Gang Forming



## Productive system

In conventional gang forming, large sections of Steel-Ply® are assembled and then moved into position by crane. Although gang forming uses the same components as handsetting, it offers several advantages. Gang forms are easily assembled on the ground and then moved into place. Stripping the unit as a gang eliminates rebuilding. This saves time and material, increases production, and reduces forming costs.

The lightweight Steel-Ply design is ideal for gangforming. At just 8 lbs. per square foot, including hardware, Walers and Strongbacks, gang form size is limited only by crane capacity.

Gang forming becomes even faster and easier with other Symons components and services. Layout drawings and training can be provided to help make gangforming as efficient and safe as possible.

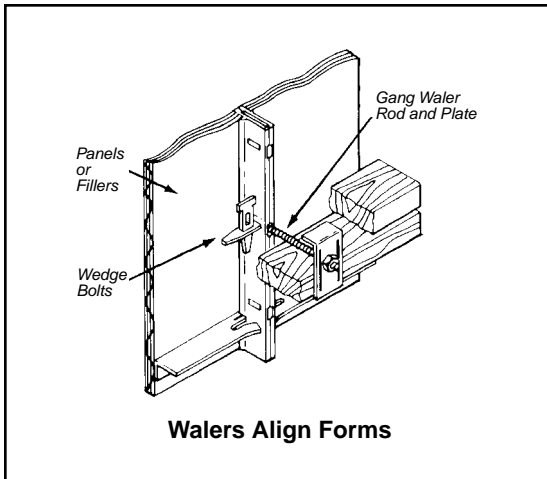

Walers Align Forms

## Gang Form Bolt

Gang Form Bolts and Wedge Bolts are used to connect panels and gang form ties. The patented Steel-Ply Gang Form Bolt connects panel siderails and gang form ties in a single operation. This longer end allows you to break the ties back and strip the gang without disassembling the forms.

## Waler

In conventional gang forming, Walers are placed 18" from the top and bottom of the gang, with one Waler for each tier of panels. These Walers align forms within the gang.

Walers are assembled using 2" x 4" or 2" x 6" lumber with Gang Waler Rods, Waler Plates, and 1/2" Contour Nuts. This arrangement provides a secure connection.

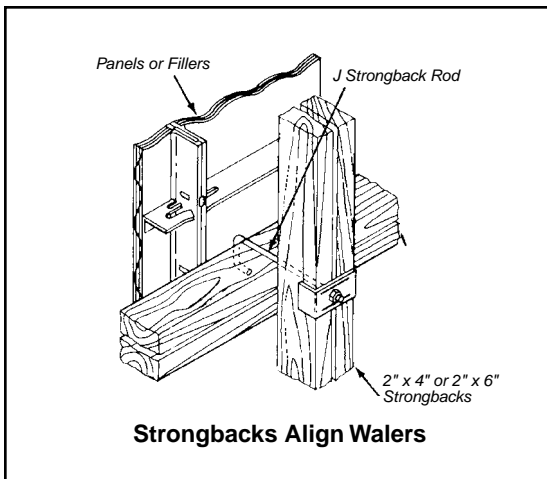

Strongbacks Align Walers

## Strongback

The same time and material advantages in waling with the Steel-Ply Forming System are also present in the use of Strongbacks which are needed only to align the Walers. They are usually placed at 8' centers, but spacing depends on the specific job conditions.

# Gang Filler

The Steel-Ply Gang Filler is designed to increase productivity by reducing the number of ties required in conventional gangforming.

This 2" steel filler features preset tie hole locations for reusable 15mm Taper Ties (1" to 3/4"), She Bolts or Tie Rods with 15mm Tie Nuts to secure the tie.

The Gang Filler is placed between each Steel-Ply panel and connected with a 3/4"x4" flat coil bolt and nut (two connections are required per filler).

The Gang Filler is available in four standard lengths: 4', 6', 8' and 10'. Gang Fillers can be stacked with Steel-Ply panels for gangs taller than 10'.

All standard Steel-Ply accessories are compatible with the Gang Filler, including the Double-Duty Lift Bracket, One-Piece Waler Bracket, Walkway Bracket and Turnbuckle.

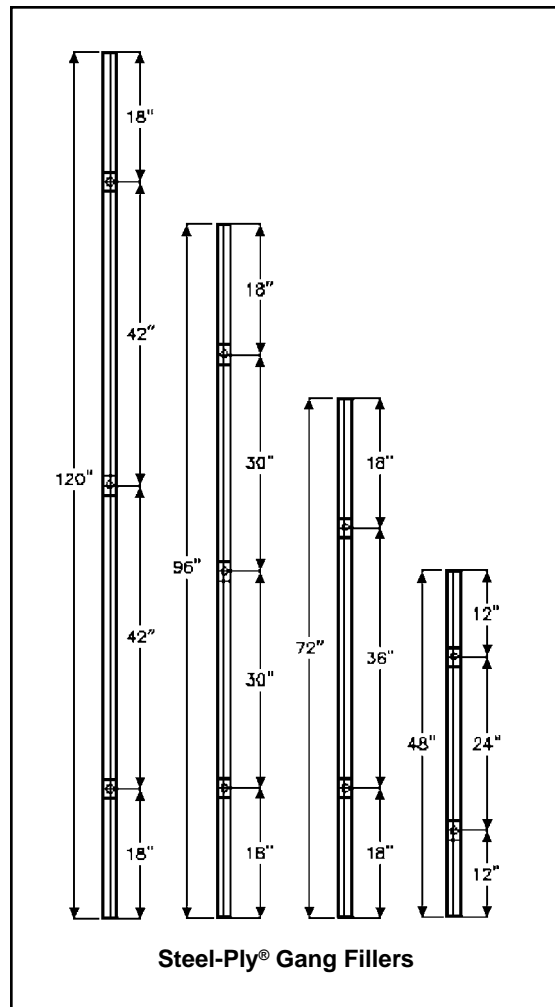

# Load-Gathering



The most economical and productive way to gangform with Steel-Ply® forming system is to use the load-gathering technique. The steel Walers and Strongbacks “gather” the load of the panels and high-capacity ties are installed through the panels and Walers. The load is transferred to the ties from the Walers.

The strength and rigidity of the Steel-Ply system allows ties to be placed farther apart than in conventional gang forming. Fewer ties saves labor when setting, stripping and patching. The placement of ties is more flexible when fewer ties are needed.

## “Y” Walls

Standard Steel-Ply components can be used to form “Y” walls of almost any angle or size. This eliminates the extra cost of custom forms that may not be reusable. Load-gathered Steel-Ply reduces the number of ties, saving labor and material for typical “Y” walls.

The standard Inside and Outside Corners and a Cantilever Bracket form trough walls. Inside and Outside Bay Corners and 45° Walers are combined with Walers and Waler Splices to form the “Y” walls.



# Heavy Duty Ties

Symons offers the most complete line of Heavy Duty ties and hardware to complement the Steel-Ply forming system.

### Heavy Duty Ties

Symons supplies 50 Kip She-Bolts or Taper Ties when 5" Walers are used. The strength of these ties, combined with the load-gathering ability of the Steel-Ply panels and Walers, permit 4' x 5' tie spacing in most gang form applications. Using fewer ties with each gang reduces overall labor and material costs.

To reduce labor even more, 85 Kip She-Bolts and 96 Kip Taper Ties are used with Steel-Ply gangs when 8" Walers are used.

### Spreader Clips

The Spreader Clip can be used with Taper Ties or She-Bolts. It is a U-shaped plate that fits over the Cast Bearing Washer and hex nut, preventing any inward movement of the gang. A tie with Spreader Clips near the bottom of the forms and one tie with Spreader Clips near the top of the form will prevent any inward movement and maintain the desired wall thickness before concrete placement.

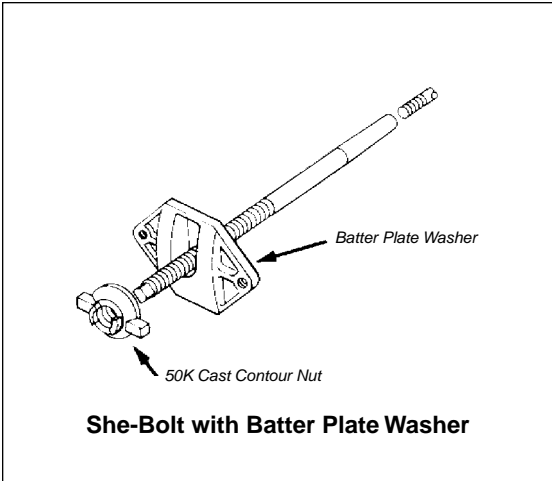
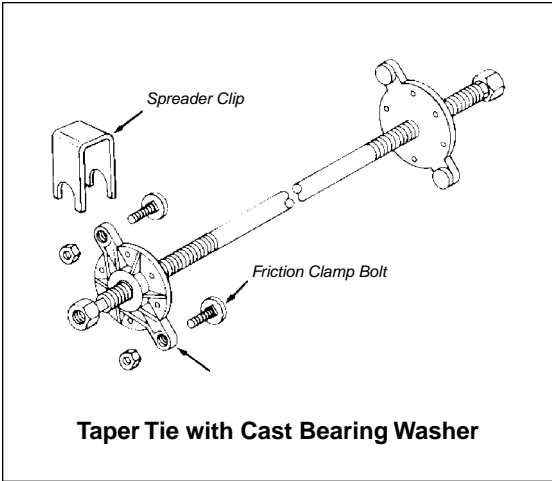
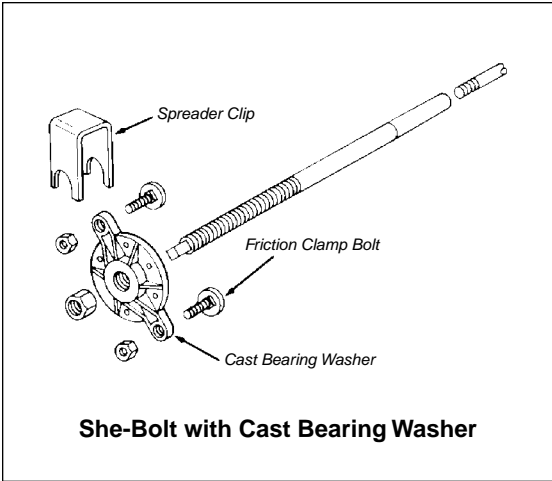

# Maxi-Waler Gang Forming

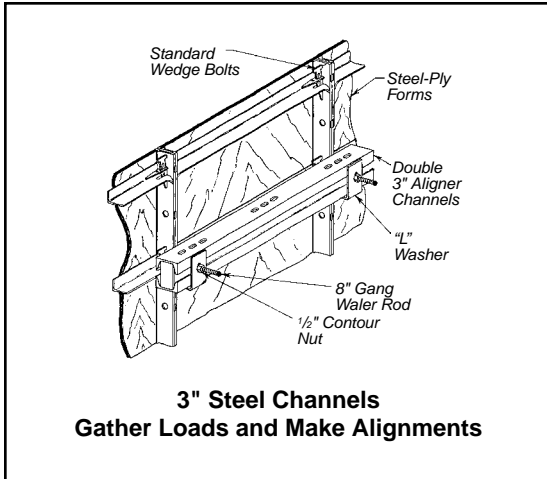

## Steel channel

The Maxi-Waler System uses double 3" steel channels attached to Steel-Ply® at 2' O.C. vertical spacing. The channel serves as both load-gathering member and aligner for the gang. "L" Washers and 8" Gang Waler Rods secure the steel channels to the forms for a positive connection.

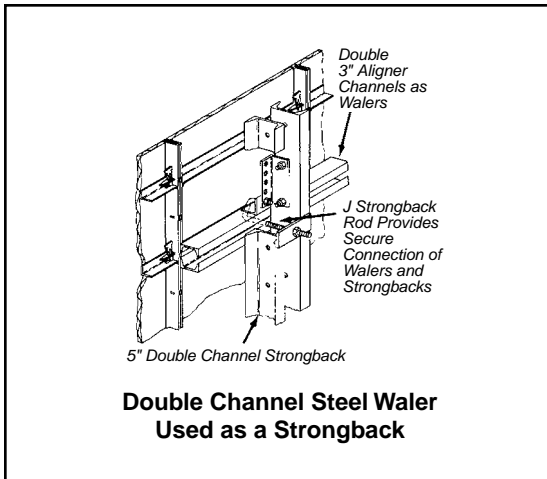

## Vertical Walers

The Maxi-Waler System uses double channel steel walers to transfer the load from the 3" channels. J-Strongback Rods and Plate Washers connect to the 3" channels at specific vertical locations. To prevent slippage, Panel Waler Connectors and Clip Angles are bolted to the Waler at two connection sites. Walers are spaced at 4' centers for maximum form design utilization.

## 5" and 8" steel Walers

For maximum form design utilization, Symons offers 5" and 8" Waler sizes. Tie areas of up to 32 square feet can be achieved, resulting in fewer ties per pour and less tie patching.

Both 5" and 8" Walers are available in standard lengths of 4', 8' 10', 12' and 16'. The 5" Walers are also available in a 6' length.

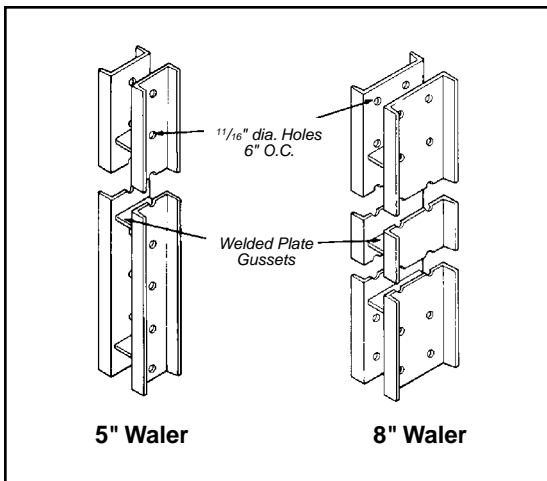

# Horizontal Gang Forming

## Horizontal Steel-Ply® gangs

Horizontal Steel-Ply gang forms utilize vertical steel Walers. This permits the use of high capacity Taper Ties or She-Bolts.

Horizontal Steel-Ply gangs are assembled using 6' and 3' panels in a "brick" pattern layout.

## Waler connection

Steel Walers are easily connected with 8" Gang Waler Rods, Plate Washers and ½" diameter Contour Nuts. Walers are placed 18" from gang ends and at 3' O.C. spacing.

## Panel Waler Connector

To prevent Waler slippage, a Panel Waler Connector is attached through the Gang Waler Rod and bolted to the steel Walers.

Panel Waler Connectors can also connect the horizontal Strongbacks to vertical steel Walers.

## Strongback

5" Walers used as Strongbacks provide stiffness and horizontal alignment to the gang. These Walers are attached with 8½" J-Bolts, Plate Washers and 5/8" Contour Nuts. Strongbacks are usually placed at the top and bottom of each gang.

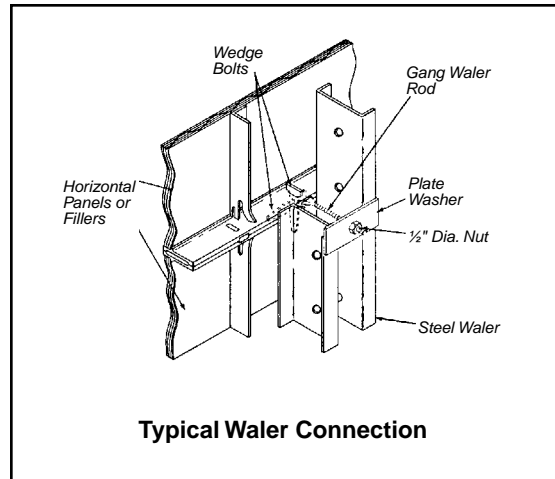

Typical Waler Connection

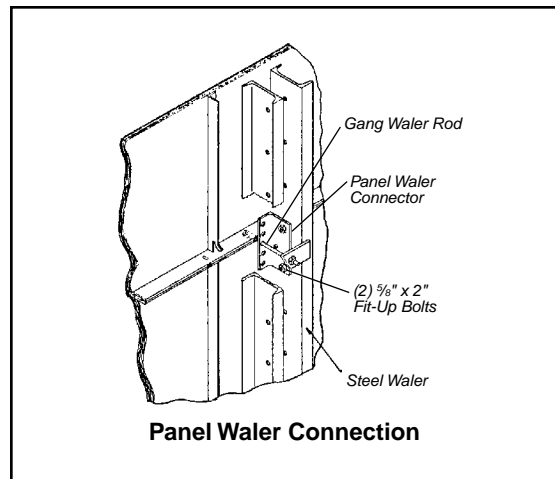

Panel Waler Connection

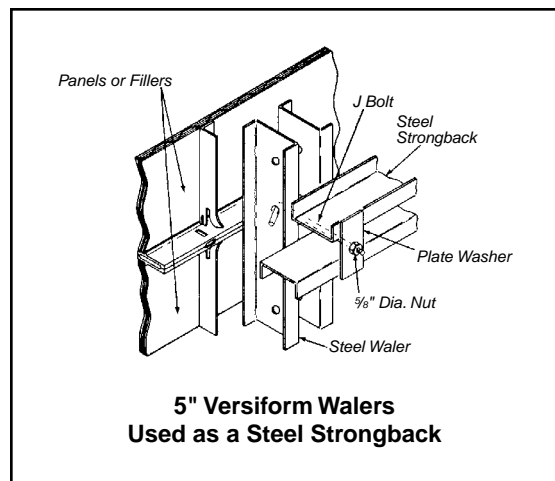

5" Versiform Walers  
Used as a Steel Strongback

# Core Wall Forming

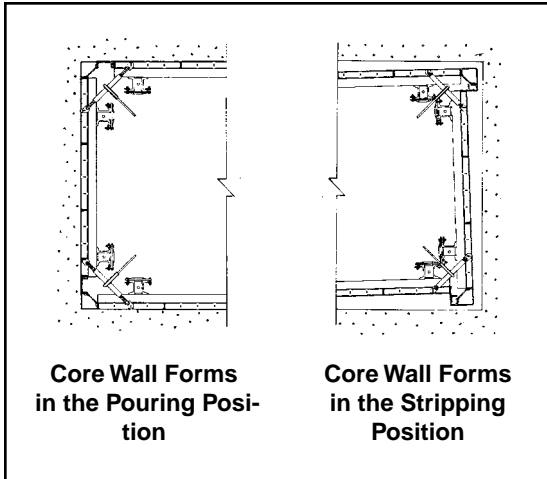

## Double Hinged Fillers

Double Hinged Fillers allow gangs for core walls and elevator shafts to be set, stripped, lifted and reset quickly. Minimal crane time is needed because they make all four sides of the gang into one movable unit.

The Double Hinged Filler is designed with two hinge points to permit inward movement when a Turnbuckle connection is retracted. After positioning the gang for the next pour, the Turnbuckles return the gang form to the rectangular shape.

Steel Walers and Strongbacks are used with high capacity She-Bolts or Taper Ties for higher productivity.

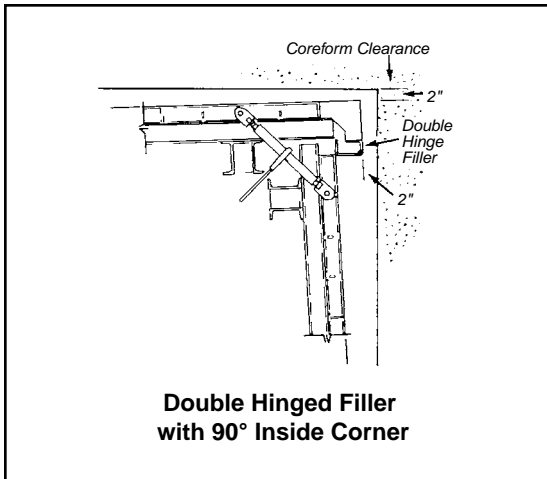

# Radius Wall Forming

## Curved Walls

The Steel-Ply® forming system can be used more efficiently than conventional job-built forms for curved walls or tank structures. Two foot wide panels readily form curved walls down to a 15' inside radius (30' diameter). Standard fillers can be used to form smaller radius walls, for example 8" fillers are used to form a 5' radius. One inch, 1½" and 2" Fillers adapt to radius walls easily with no "cut-up" construction. A simple program is used to calculate the number and sizes of panels and filler needed. A layout will show where every piece is located on the curved wall.

In most cases, Walers and Strongbacks are needed only on walls higher than 10'. Only the inside wall formwork needs to be braced, saving time and materials.

On high walls that need Walers and Strongbacks, special Waler Brackets can be used. Brackets for 2" x 4" or 2" x 6" lumber and Pipe Walers are available for fast Waler attachment. No blocking or shimming is needed.

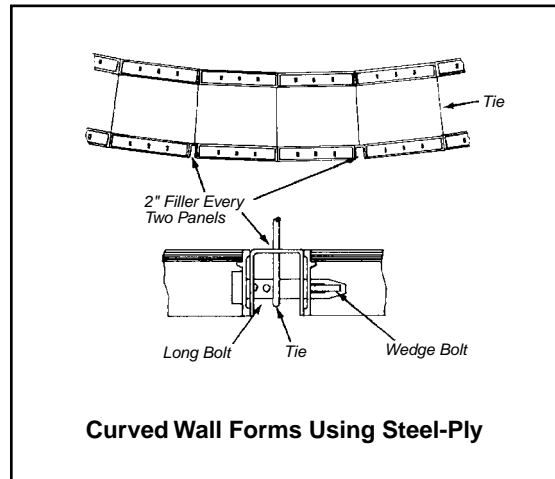

**Curved Wall Forms Using Steel-Ply**

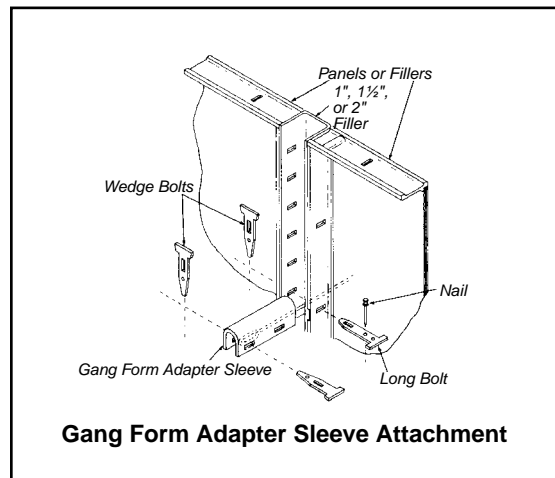

**Gang Form Adapter Sleeve Attachment**

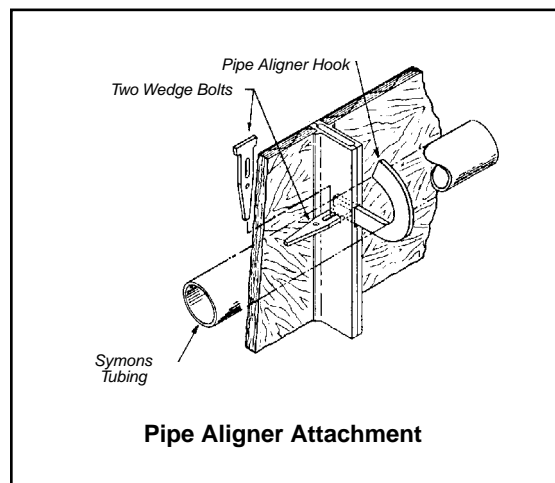

**Pipe Aligner Attachment**

# Transition Forming

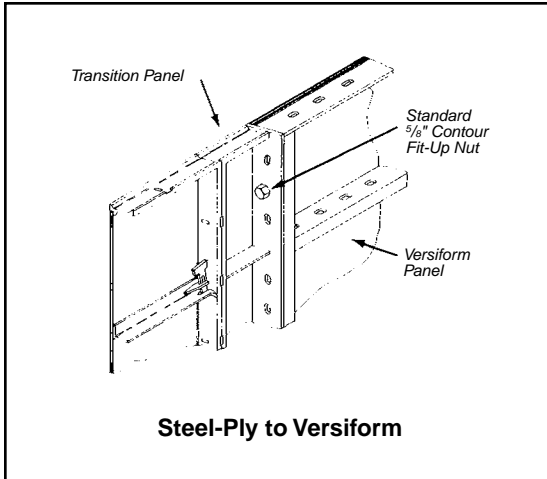

## Steel-Ply® to Versiform®

Transition bolts, panels and corners allow quick and easy connection between Steel-Ply and Versiform. This combination provides the versatility and quality that intricate forming details require.

## Steel-Ply to Max-A-Form®

Steel-Ply panels and fillers connect directly to Max-A-Form with Wedge Bolts. This combination provides the strength and gang forming advantages of Max-A-Form with Steel-Ply versatility for details.

## Steel-Ply to Flex-Form®

Steel-Ply panels and fillers connect directly to Flex-Form with Wedge Bolts. This combination provides the strength and gang forming advantages of Max-A-Form with Steel-Ply versatility for details.

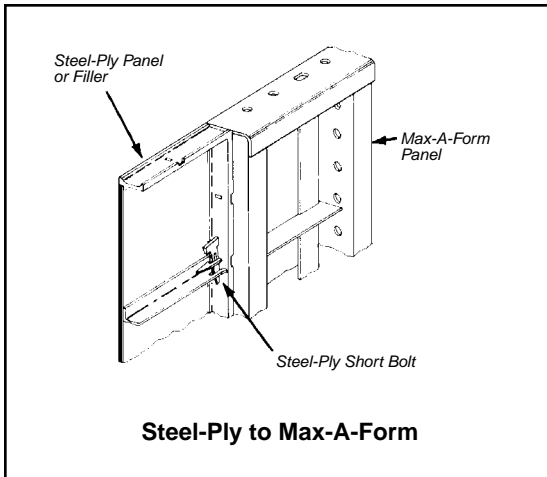

## Steel-Ply to Alisply™

The 8" Symons Alisply Transition Filler provides a convenient connection between the clamp-style Alisply gangform system and almost any other Symons concrete forming system, including Steel-Ply. The filler allows the Alisply gangs to be used for large areas, and Steel-Ply components to be used for detail areas, without time-consuming job-built fillers.

## Steel-Ply to Rasto™

The 6" Symons Rasto Transition Filler provides a convenient connection between the clamp-style Rasto system and the Steel-Ply system. Two different forming systems can be used effectively on the same project with this unique component.



## Attached hardware option

Residential and other repetitive handset jobs are perfect applications for the time-saving attached hardware feature. In this system, panels are supplied with the connecting Drop Bolts and Slide Bolts already attached. Since connecting bolts are already attached at the tie locations, workers immediately know where to position each tie.

An attached Hardware Kit is also available for contractors who wish to retrofit Steel-Ply® panels and fillers they already own.

## Beam Pocket

The Beam Pocket is a reusable tapered steel boxout that leaves a void pocket at the top of the foundation wall for steel or wooden beams. The standard 6" x 8" x 4" deep size comes with a handle for easy carrying and removal.

## Steel-Ply to Symons Silver™

The Steel-Ply/Symons Silver Transition Filler provides a convenient connection between these two systems. Since many Steel-Ply components are rentable, the two systems can be combined on big jobs, eliminating the need to purchase additional aluminum forms.

## Steel-Ply to Resi-Ply™

The Steel-Ply/Resi-Ply Transition Filler provides a connection between these two systems. Since many Steel-Ply components are rentable, the two systems can be combined on big jobs, eliminating the need to purchase additional 1½" forms.

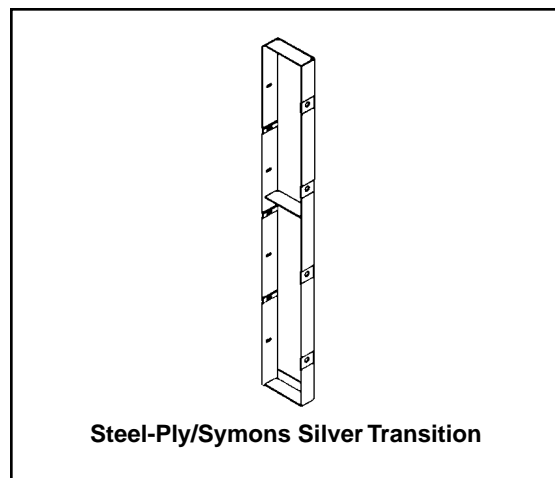
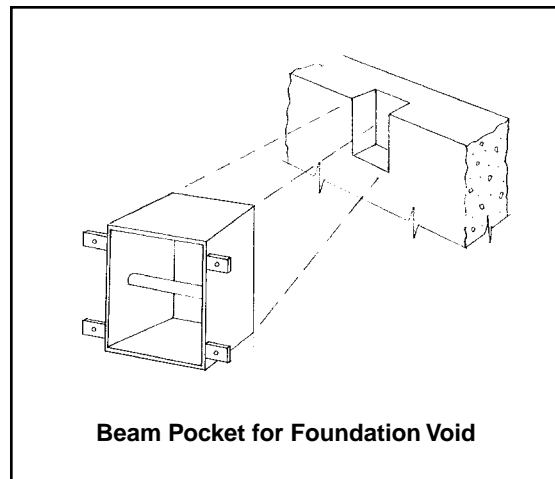
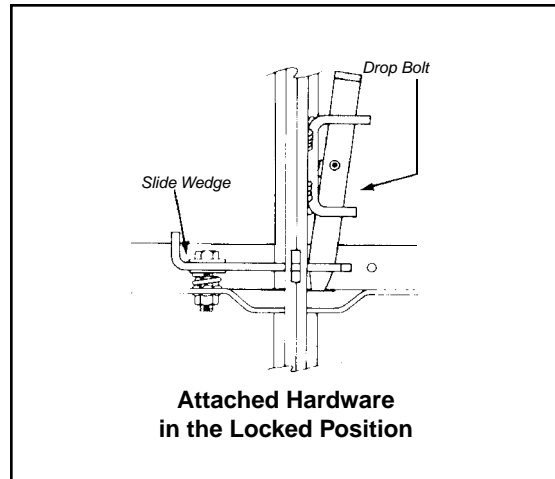



**Adjustable Column Form** — Form square or rectangular columns efficiently with a minimum number of steel panels.

**Alisply™** — Clamp-type, metric-dimension system is quickly assembled and reconfigured for fast-paced gangforming.

**Aluminum Beams and Joists** — Lightweight beams/ joists from 4' to 30' (122cm to 914cm) for deck or gangform applications.

**Box Culvert Traveler** — Rolling steel framework is compatible with Steel-Ply, Versiform and Max-A-Form systems.

**Chemicals** — Liquid, cement, epoxy and other specialty products for concrete construction and repair.

**DeckFast™** — A quick two-component system of modular panels and shores for creating flat concrete decks.

**Flex-Form®** — Specially designed steel-faced system for forming curved walls and round tanks with no surface “chording”.

**Form Liner** — More than 100 standard patterns, in four different materials, create unique concrete textures.

**FrameFast™** — Provides 24,000 lb. (106kN) load capacity per shore frame with spacings from 3' to 15' (91.4cm to 457.2cm).

**Garage Beam** — A complete system to form an economical, poured-in-place concrete parking garage.

**Max-A-Form®** — A durable, all-steel forming system that is ideal for pier caps and self-spanning applications.

**Rasto™** — The advantages of a clamp-type gangform, with the handset flexibility for details.

**Resi-Ply™** — A low cost, 1½" (2.9cm) plywood forming system for residential construction, in 4-bar, 5-bar and 6-bar spacing.

**Roller Deck** — Column-mounted deck support system replaces conventional shoring, providing access for other trades.

**Room Tunnel** — One room per day, per form provides maximum forming productivity for repetitive room designs like hotels.

**ShorFast™** — High capacity aluminum leg and jack shoring system can support up to 30 kips (133kN) per leg.

**Steel-Ply®** — The most recognized modular system, with more than 80 panel and filler sizes, for handsetting or gangforming.

**Street Smart™** — Reusable steel forms for residential curb and gutters, industrial slabs and highway paving applications.

**Symons Silver™** — A lightweight aluminum system that makes residential forming operations efficient and productive.

**Symons Soldier™** — The “next generation” construction beam that can be used as a brace, strongback, waler or shore.

**Truss** — Crane handling of large aluminum tables increases deck forming productivity for repetitive bays.

**Versiform®** — Steel frame/plywood face gangforming system that provides a smooth concrete finish.

Printed in U.S.A.  
© 2007, Symons  
Product Code 99455

